



- **Reliable 63kW (84hp) Turbocharged JCB Dieselmax engine provides proven power when you need it**
- **4 Forward – 4 Reverse JCB Synchro Shuttle transmission allows you to select the right gear for the application**
- **A choice of 2600kg (926), 3000kg (930) and 4000kg (940) gives an excellent range of weight lifting capabilities**
- **Low service downtime means more time performing and earning**
- **A range of different sized masts to suit various applications**

# Rough terrain fork lifts

**Lift capacities of 2.6 to 4 tonnes and lift heights from 3.6 to 6.70m**

**63kW (84hp) engine delivers powerful performance**

**JCB Synchro Shuttle transmission gives fast, smooth directional change**

**Choice of mast heights, attachments and carriage types adapts the machine to your needs**

**Sideshift gives accurate placing of materials on scaffolding**



Docks, yards, special events, timber forestry, construction sites, builders' merchants... JCB rough terrain fork lifts (RTFL) are the reliable, versatile and easy-to-use solution for virtually any rehandling environment you can think of.

Designed for high mobility and superb productivity in rough terrain areas, there are three RTFLs in the JCB range with lift capacities of 2.6 to 4 tonnes and lift heights from 3.6 to 6.7 m. At the heart of each machine, all of which come as two or four-wheel drive, is a 63kW (84hp) JCB Dieselmix engine delivering powerful performance. The JCB Synchro Shuttle transmission with integral torque converter gives fast, smooth directional change, while the four-speed synchromesh gearbox and Max-Trac axles give top performance and drive over the roughest ground.

JCB RTFLs allow you to choose between four different mast heights, each one designed for excellent forward visibility and offering up to 18° of forward tilt to assist load handling and placement. In addition, the sideshift function makes placing materials on scaffolding much easier. To cover all applications and optimise versatility, there is also a selection of attachments, three carriage types and a range of tyres to suit various applications and environments.

Add all of this to an operator environment that is designed for comfort and all-round visibility, along with proven, reliable technology and superb serviceability, and you have a rehandling solution with a huge amount of potential.







OPERATING WEIGHTS: 5910 to 7500kg (13029 to 16535lb) LIFT CAPACITY: 2.6 to 4.0 tonnes (5732 to 8818lb)

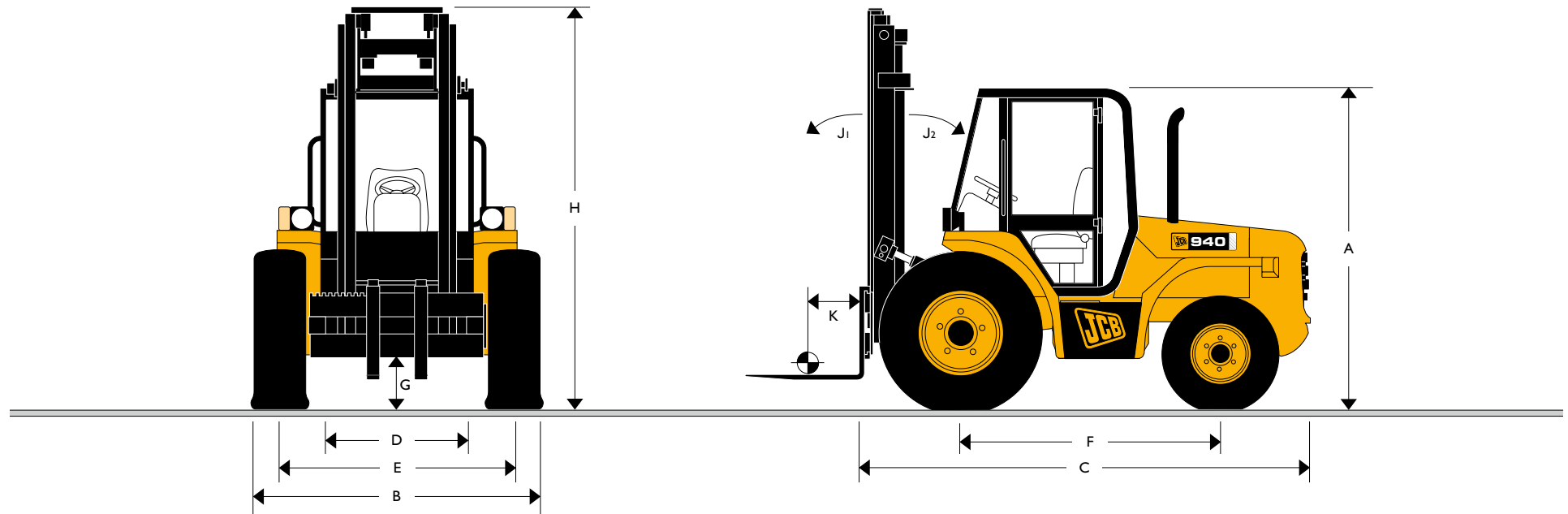

### DIMENSIONS

Machine model	926	930	940
	m (ft-in)	m (ft-in)	m (ft-in)
A Overall cab height	2.57 (8-5)	2.57 (8-5)	2.57 (8-5)
B Overall width (over tyres)	2.20 (7-2½)	2.20 (7-2½)	2.20 (7-2½)
C Overall length to front carriage (industrial or bar)	3.60 (11-10)	3.60 (11-10)	3.60 (11-10)
D Inside width of cab	1.10 (3-6)	1.10 (3-6)	1.10 (3-6)
E Front track	1.80 (5-11)	1.80 (5-11)	1.80 (5-11)
F Wheel base	2.10 (6-9)	2.10 (6-9)	2.21 (7-2)
G Ground clearance	0.30 (0-10)	0.30 (0-10)	0.30 (0-10)
H Mast closed height			
3.6m mast	3.00 (9-8)	3.00 (9-8)	2.85 (9-4)
4.5m mast	2.41 (7-10)	2.41 (7-10)	2.50 (8-2)

Machine model	926	930	940
5.5m mast	3.00 (9-8)	3.00 (9-8)	2.80 (9-2)
6.55m mast	3.32 (10-11)	3.32 (10-11)	Not available
6.70m mast	Not available	Not available	3.25 (10-8)
Mast open height			
3.6m mast	4.78 (15-8)	4.78 (15-8)	4.84 (15-10)
4.5m mast	5.41 (17-9)	5.41 (17-9)	5.81 (19-1)
5.5m mast	6.65 (21-8)	6.65 (21-8)	6.73 (22-1)
6.55m mast	7.67 (25-2)	7.67 (25-2)	Not available
6.70m mast	Not available	Not available	7.84 (25.9)
J1 Mast tilt forwards	18°	18°	10°
J2 Mast tilt backwards	10°	10°	10°
K Load centre	0.50 (1-8)	0.50 (1-8)	0.50 (1-8)

The above data based on the following specification: Standard fork size 1067 x 100 x 50 mm (42 x 4 x 2 in)



### TURN RADIUS & GROUND LINE ANGLES

Machine model		926	930	940
Outside turn radius 2WD	m (ft-in)	4.38 (14-4)	4.38 (14-4)	4.45 (14-5)
Outside turn radius 4WD	m (ft-in)	4.35 (14-3)	4.35 (14-3)	4.92 (16-1)
Departure angle		53°	53°	53°
Obstruction angle		51°	51°	51°

The above data based on the following specification: Standard fork size 1067 x 100 x 50 mm (42 x 4 x 2 in)

### WEIGHT

Machine model		926	930	940
Overall weight	kg (lb)	5910 (13025)	6340 (13973)	7500 (16535)

The above data based on the following specification: Standard fork size 1067 x 100 x 50 mm (42 x 4 x 2 in)

### ENGINE

		926/930/940
Model		JCB Diesel TC-63
Displacement	litres	4.4
Fuel		Diesel
Cooling		Liquid
Bore	mm	103
Stroke	mm	132
Gross power – ISO 14396 @ 2200rpm	kW (hp)	63.0 (84)
Gross torque – ISO 14396 @ 1300rpm	Nm (lbf ft)	350 (258)
Emission certification		EC Stage IIIA/USA EPA Tier 3
Engine oil service intervals		500 hours

### TRANSMISSION

For unbeatable drive power in all conditions, the JCB Synchro Shuttle combines a 4-speed, fully synchromesh gearbox with integral torque converter and electrically operated reversing shuttle for smooth gear changes on the move and fast cycle times. Column mounted electric switch effortlessly controls machine direction changes allowing operator to keep hands on steering wheel. Automotive style pedal layout and conventional H-pattern gear lever add to ease of operation. Travel speed 29kph (18mph).

- Front drive axle:** JCB epicyclic hub reduction drive axle with Max-Trac torque proportioning differentials.
- Rear steer axles:** JCB manufacture with hydrostatic power steering. Steer shock valve as standard.  
4WD versions with epicyclic hub reduction and Max-Trac torque proportioning differentials.

### BRAKES

- Service brakes:** Hydraulically activated, self-adjusting, oil-immersed in-board multi-disc type in front axle (926/930). Optional Hydraulic Servo assisted, self adjusting brakes on (926/930) standard on 940.
- Parking brake:** Hand operated disc brake on output of gearbox.

### MASTS AND CARRIAGES

Clearview masts manufactured from channel and I-section steel. Heavy duty mast chains. Guide roller bearings are sealed for life. Industrial class IIIB carriage, or bar carriage available for all masts. All carriages have side thrust rollers. Adjustable right hand tilt ram.

### TYRES

Machine model		926	930	940
Standard tyres		16.5/85-24	16.5/85-24	16.5/85-24
(UK) Front		Traction	Traction	Traction
Rear 2WD		12.5/80-18	12.5/80-18	12.5/80-18
		Rib and bar	Rib and bar	Rib and bar
Rear 4WD		12.5/80-18	10.5-18	12.5/80-18
		Traction	Traction	Traction

### HYDRAULICS

Single gear pump with steer priority valve, suction strainer and filter. Operating system pressure: 221 bar (3200psi), flow 55 ltr/min (12.5gal/min). Pipe burst protection on mast hydraulics.

### AUTOMATIC DERATION

Deration valve: 5.5m, 6.55 and 6.70m masts are fitted with a deration valve which automatically reduces lift capacity above 4.5m for safety and stability.

### SERVICE CAPACITIES

	litres (UK gal)
Fuel tank	88 (19.0)
Hydraulic tank	60 (13)
Coolant	17 (3.7)

### ELECTRICS

12v negative earth. 95Ah battery. 65 amp alternator. Full road lighting, direction indicators, hazard warning reverse and fog light.

### OPERATOR MODULE

- Safety quiet cab or canopy, FOPS standard (falling object protective structure) to FEM Section IV and ANSI B56.6 – 1978.
- Cab:** Resiliently mounted, two door access, level floor with mat, safety glass all round with laminated roof window, bolt on roof bars. Fitments include: velour seat, rear view mirror and 2 speed heater/demister. Front/Rear screen wiper and washer, horn. Handbook. Instruments for hourmeter battery charge. Audible/Visual warning system for alternator charge, coolant temperature, engine oil pressure, blocked air filter, transmission oil pressure and temperature. Warning lights for: main beam, hazard warning, park brake on, direction indicators. Hydraulic control levers, gear lever, park brake, forward/reverse lever, 4WD disconnect, throttle, brake, and transmission disconnect pedal.
- Canopy:** As above but with no glazing (screen wiper and heater/screen demister not applicable), and rear fenders are standard.

### OPTIONS AND ATTACHMENTS

Auxiliary carriage services via hose reel for powered attachments. Wheel and tyres sets. Tinted cab glazing. Suspension seat. Seat belt. Roof screen wash/wipe. Flashing roof beacon. Fire extinguisher. Cab exterior mirrors. Front screen bars. Optional rear fenders. Reversing lights. Propshaft guards. Chaff guard. Air pre-cleaner. Engine fan guard kit. Hose guard kits. Load guard. Contact your local dealer for details of the comprehensive range of attachments.



### 926 CAPABILITIES

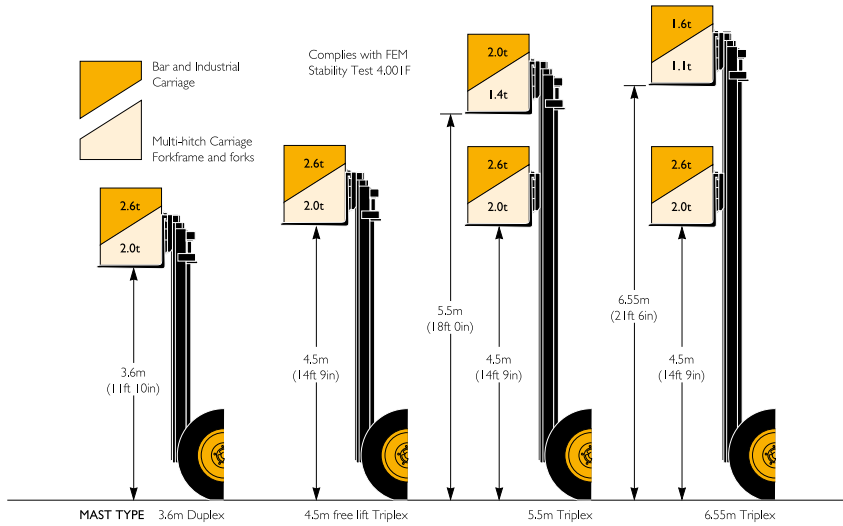

### 940 CAPABILITIES

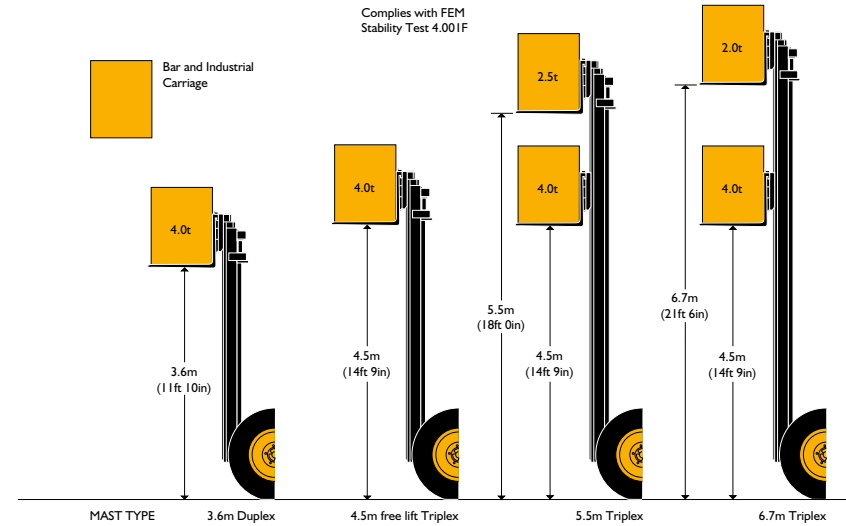

### 930 CAPABILITIES

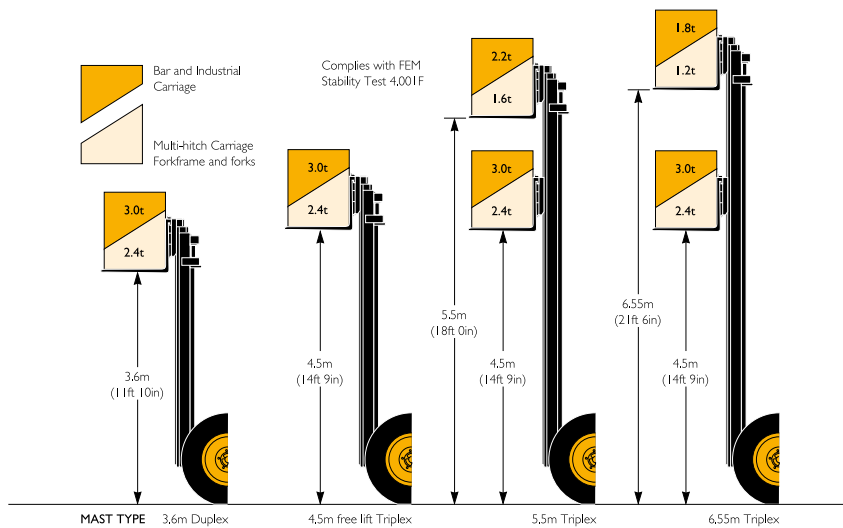





JCB Sales Limited, Rocester, Staffordshire, United Kingdom ST14 5JP. Tel: +44 (0)1889 590312 Email: [salesinfo@jcb.com](mailto:salesinfo@jcb.com)  
Download the very latest information on this product range at: [www.jcb.com](http://www.jcb.com)

©2009 JCB Sales. All rights reserved. No part of this publication may be reproduced, stored in a retrieval system, or transmitted in any form or by any other means, electronic, mechanical, photocopying or otherwise, without prior permission from JCB Sales. JCB reserves the right to change specifications without notice. Illustrations and specifications shown may include optional equipment and accessories. The JCB logo is a registered trademark of J C Bamford Excavators Ltd.